



Project _____

Item No. _____

Quantity _____

INCOGNEETO™ Under-Counter Buffet Warmer



PERFORMANCE

The CookTek® Incogneeto™ is an under-counter buffet warmer designed to mount under natural stone or “engineered” stone countertops – no cutting of the stone is required. The Magneeto™ trivet (one included with purchase) is placed on the countertop and acts as a temperature sensor, communicator, and locator device which allows the efficient heating of any induction-compatible pan through the stone countertop.*



(CROSS-SECTION VIEW)

- 1. Chafing Dish
- 2. Magneeto™ 2 Trivet
- 3. Stone Countertop
- 4. Plywood Substrate
- 5. Incogneeto™ Unit

FEATURES

- Models available in 650 watts
- Under-the-counter design with a polycarbonate top and aluminum housing
- Magneeto™ trivet locates heat zone when placed on countertop – one included with purchase
- Accommodates up to a 12” (305 mm) induction-compatible enamel cast ironware or traditional chafer
- Can be safely used under natural stone or engineered “stone” countertops
- Automatic pan detection allows for instant energy transmission to pan; almost no energy consumption when pan is not present
- Lock feature prevents unwanted setting changes
- Standard Cat 5e or Cat 6 patch cable from unit to control box included
- Available in 100–120 VAC or 200–240 VAC, single phase
- Includes plug and cord (6 ft. nominal)
- One-year field-service warranty – U.S. and Canada

ACCESSORIES (NOT INCLUDED)

- Additional Magneeto™ Trivet (Part # INC-3000)
- Large Round Chafer, 6.9 qt, Glass Lid with 1/1 SS Insert (Part # 301311)
- Large Round Stainless Insert, 1/1 (Part # CT-103128)
- Large Round Stainless Insert Split Pan, 2/2 (Part # CT-103771)
- Large Round Porcelain Insert, 1/1 (Part # CT-103095)
- Large Round Porcelain Insert Split Pan, 2/2 (Part # CT-103096)
- Medium Round Chafer, 4.8 qt, Glass Lid with 1/1 SS Insert (Part # 301309)
- Medium Round Stainless Insert, 1/1 (Part # CT-103129)
- Medium Round Porcelain Insert 1/1 (Part # CT-103094)
- Serving Spoon Holder, Large or Medium (Part # CT-103097)



INC-3000



301311 (Large)
301309 (Medium)



CT-103128 (Large)
CT-103129 (Medium)



CT-103771
(Large)



CT-103095 (Large)
CT-103094 (Medium)



CT-103096 (Large)



CT-103097
(Large or Medium)

CERTIFICATIONS



*Induction buffet units require the use of induction-compatible (i.e. magnetic) cookware.

It is the owner and installer’s responsibility to comply with all local codes. CookTek reserves the right to make substitutions of components or change specifications without prior notice.

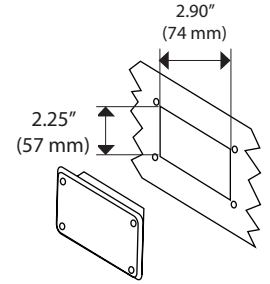
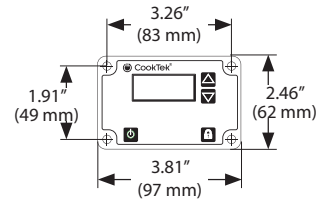
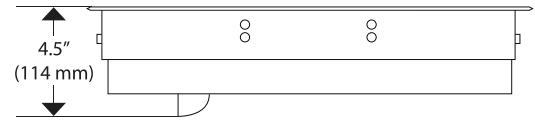
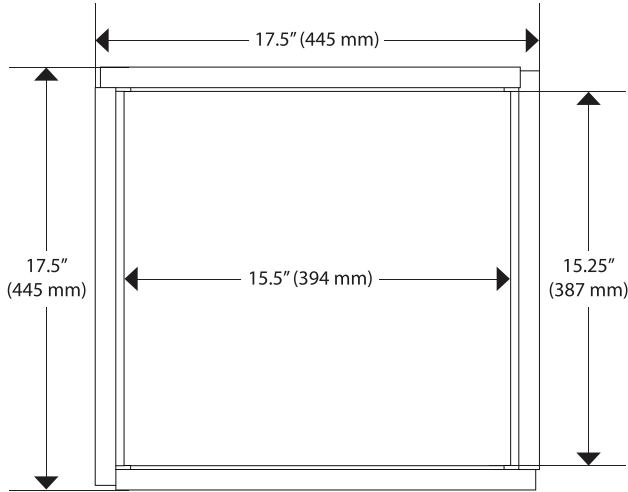

DIMENSIONS		
Unit Height	4.5"	114 mm
Unit Width	17.5"	445 mm
Unit Depth	17.5"	445 mm
Interior Surface Width	15.5"	394 mm
Interior Surface Depth	15.25"	387 mm
Weight	15 lb.	6.8 kg
Max Ambient Temperature	122°F	50°C
CLEARANCE		
Front	2"	51 mm
Sides	2"	51 mm
Below*	6"	152 mm
COOLING REQUIREMENTS AND SPECIFICATIONS*		
Min. Ventilation Requirements	16 in ²	103 cm ²
Internal Cooling Fan Displacement	70 CFM (2.0m ³ /min)	
SHIPPING INFORMATION		
Packaged Height	10"	254 mm
Packaged Width	21"	533 mm
Packaged Depth	21"	533 mm
Packaged Weight	18 lb.	8 kg
Item Class	250 NMFC #26710	

* See document CT-104648 for complete Incoigneeto™ installation instructions.

ELECTRICAL SPECIFICATIONS (SINGLE PHASE)			
MODEL B651-U2			
UNITED STATES/ CANADA	660801	100–120 V, 50/60 Hz, 6 A, 100–650 W	NEMA 5-15P
MODEL B652-U2			
UNITED STATES/ CANADA	660901	200–240 V, 50/60 Hz, 4 A, 100–650 W	NEMA 6-20P
UK/SAUDI ARABIA	660902	200–240 V, 50/60 Hz, 4 A, 100–650 W	BS1363, 13A, 230V
INTERNATIONAL	660903	200–240 V, 50/60 Hz, 4 A, 100–650 W	CEE 7/7 Schuko, 16A, 250V
AUSTRALIA	660904	200–240 V, 50/60 Hz, 4 A, 100–650 W	AS/NZ 3112:2000, 10A, 250V
SOUTH AFRICA	660907	200–240 V, 50/60 Hz, 4 A, 100–650 W	BS 546, 16A, 250V
ISRAEL	660908	200–240 V, 50/60 Hz, 4 A, 100–650 W	SI 32, 16A, 250V

Dedicated circuit required for each installation.

	NEMA 5-15P		AS/NZS 3112:2000, 10A, 250V
	NEMA 6-20P		BS 546, 16A, 250V
	BS1363, 13A, 230V		CEE 7/7 Schuko, 16A, 250V
	SI 32, 16A, 250V		

Global Operations

2801 Trade Center Drive / Carrollton, Texas 75007 USA
 US: 800.90TURBO (800.908.8726) / International: +1 214.379.6000
 Fax: +1 214.379.6073 / www.cooktek.com